

ISOMETRIC VIEW

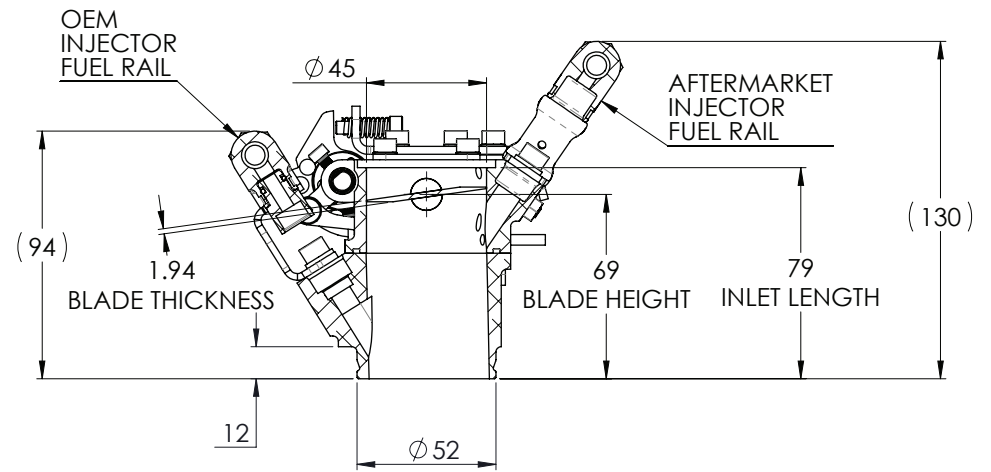

SECTION A-A



COPYRIGHT (c) 2013  
AT POWER LTD  
UNIT 9, CHESTNUT DRIVE, WYMONDHAM,  
NORFOLK, UK, NR18 9SB

UNLESS OTHERWISE STATED:  
DIMENSIONS IN MILLIMETRES  
TOLERANCES: LINEAR ± 0.1 ANGULAR ± 0.5°  
SURFACE FINISH √ = √  
DRAWING STANDARDS TO ATQS 6003  
DATE FORMAT: DD/MM/YY

THIS DESIGN IS THE PROPERTY OF  
AT POWER THROTTLES LTD AND  
MUST NOT BE REPRODUCED OR  
COMMUNICATED WITHOUT  
AUTHORITY

CAD PLOT  
DO NOT  
SCALE

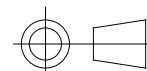

THIRD ANGLE PROJECTION

SCALE 1:2 WEIGHT 2.2 kg

DRAWN- S.HOW

DATE - 11/11/20

CHECKED - S.HOW

APPROVED - A.CLIFTON

MATERIAL

SEE COMPONENT PARTS

FINISH

SEE COMPONENT PARTS

DRAWING TITLE

ASSY - HOUSING - TWIN -  
HAYABUSA - GEN 2 - 45MM -4X  
PICOS 4X OEM INJECTORS

DRAWING NUMBER

102-104-00034

SHEET 2 OF 2 A3