

NOTES:

1. DISPLACEMENT PER REVERLUTION PER STAGE = 14.3 CC/REV
2. DISPLACEMENT AT 1000 RPM = 14.3 LT/MIN
3. PRV CRACKING PRESSURE:-  
 MINIMUM = 2.9 BAR (42 PSI)  
 MAXIMUM = 8.27 BAR (120PSI)
4. FOR EACH FULL TURN OF THE ADJUSTER THE CRACKING PRESSURE WILL INCREASE/DECREASE BY 0.25 BAR (3.6 PSI)

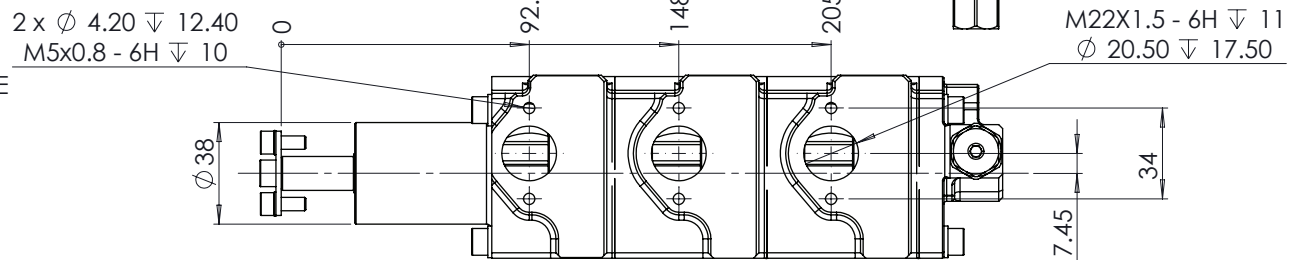
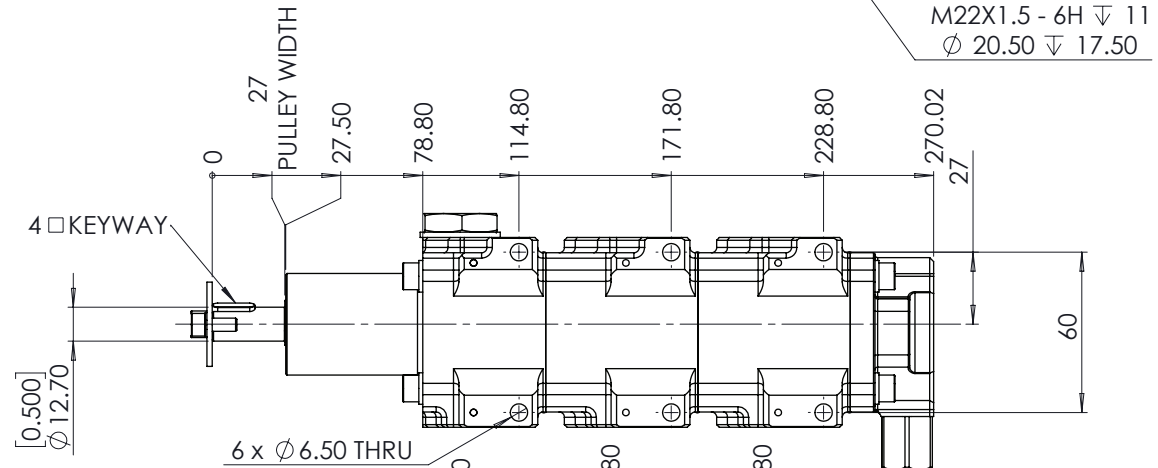
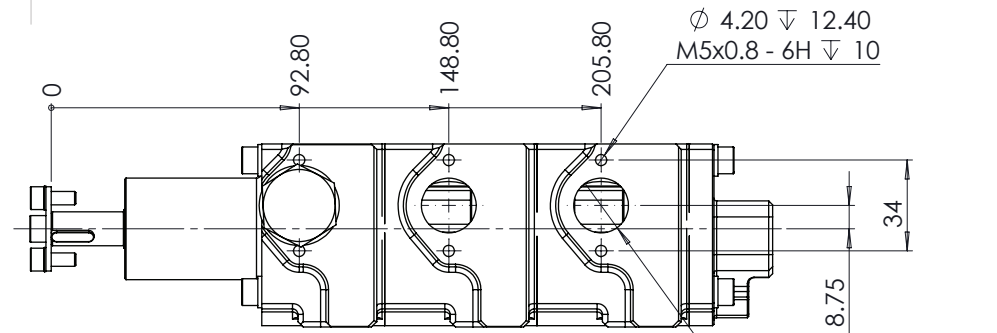
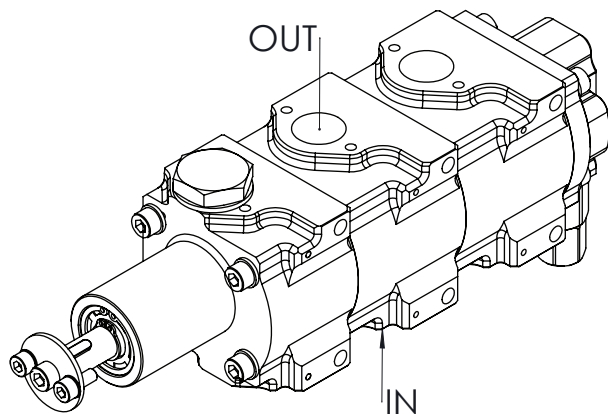
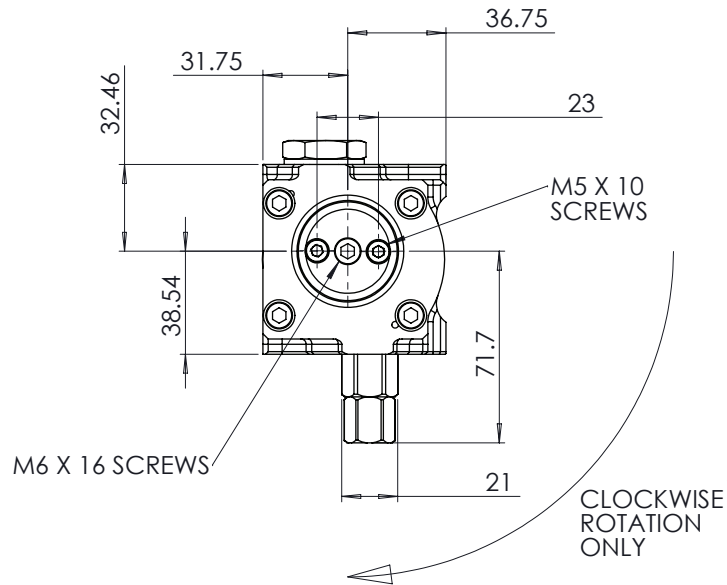

COPYRIGHT (c) 2013  
 AT POWER LTD  
 UNIT 9, CHESTNUT DRIVE, WYMONDHAM,  
 NORFOLK, UK, NR18 9SB

UNLESS OTHERWISE STATED:  
 DIMENSIONS IN MILLIMETRES  
 TOLERANCES: LINEAR  $\pm 0.1$  ANGULAR  $\pm 0.5^\circ$   
 SURFACE FINISH  $\nabla = \nabla$   
 DRAWING STANDARDS TO ATQS 6003  
 DATE FORMAT: DD/MM/YY

THIS DESIGN IS THE PROPERTY OF  
 AT POWER THROTTLES LTD AND  
 MUST NOT BE REPRODUCED OR  
 COMMUNICATED WITHOUT  
 AUTHORITY

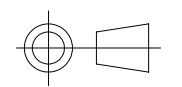

THIRD ANGLE PROJECTION

SCALE 1:2 WEIGHT 2.4 kg

DRAWN- S.HOW

DATE - 21/04/20

CHECKED - S.HOW

APPROVED - A.CLIFTON

MATERIAL  
 SEE COMPONENT PARTS

FINISH  
 SEE COMPONENT PARTS

DRAWING TITLE  
 3 STAGE CORDIS-PRESSURE  
 PUMP-LONG NOSE-14.3 Lt

DRAWING NUMBER  
 104-103-00088