

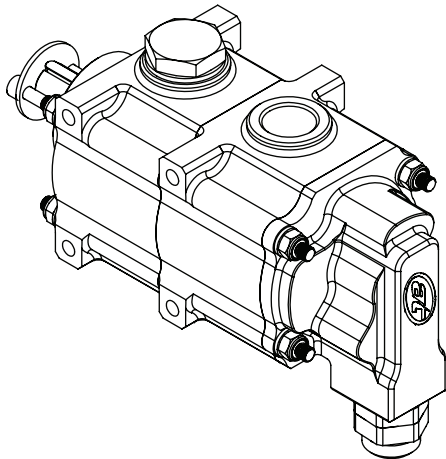

NOTES:

1. DISPLACEMENT PER REVERLUTION PER STAGE = 22.0 CC/REV
2. DISPLACEMENT AT 1000 RPM = 22.0 LT/MIN
3. PRV CRACKING PRESSURE:-  
 MINIMUM = 1.6 BAR (24 PSI)  
 MAXIMUM = 8.7 BAR (126PSI)
4. FOR EACH FULL TURN OF THE ADJUSTER THE CRACKING PRESSURE WILL INCREASE/DECREASE BY 0.41 BAR (6.0 PSI)

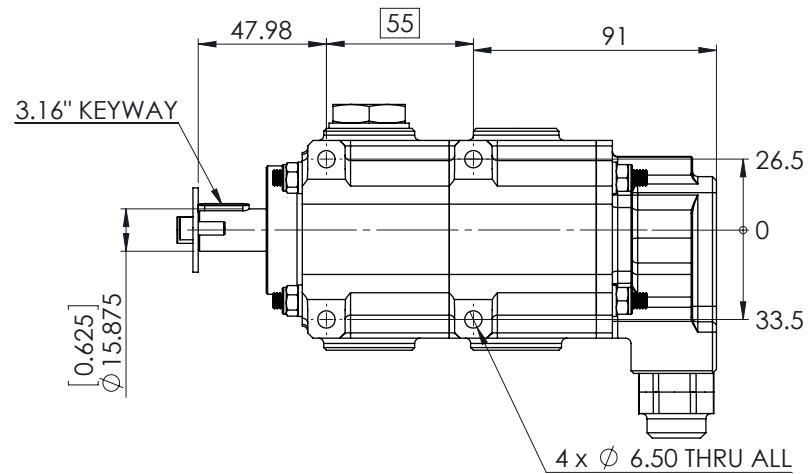
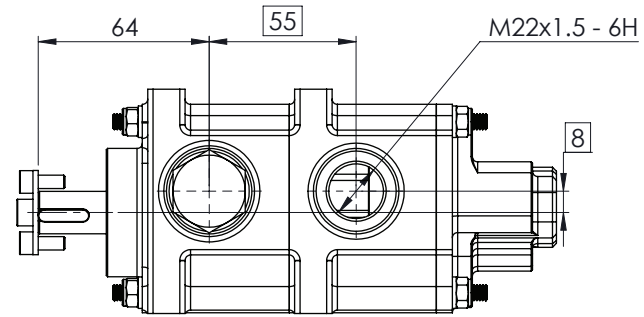
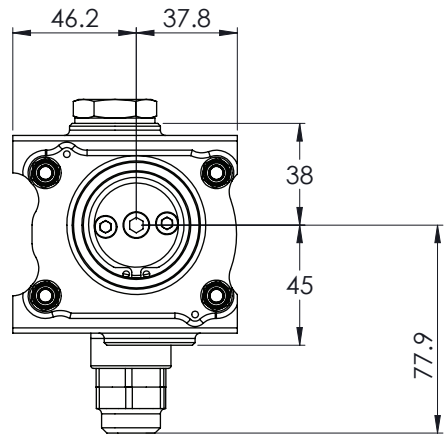

ISOMETRIC VIEW

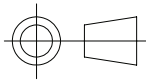
 COPYRIGHT (c) 2013 AT POWER LTD UNIT 9, CHESTNUT DRIVE, WYMONDHAM, NORFOLK, UK, NR18 9SB	 THIRD ANGLE PROJECTION	MATERIAL	SEE COMPONENT PART	
		FINISH	SEE COMPONENT PART	
UNLESS OTHERWISE STATED: DIMENSIONS IN MILLIMETRES TOLERANCES: LINEAR ± 0.1 ANGULAR ± 0.5° SURFACE FINISH √ = √ DRAWING STANDARDS TO ATQS 6003 DATE FORMAT: DD/MM/YY	SCALE	1:2	WEIGHT	2.5 kg
	DRAWN-	S.HOW		
THIS DESIGN IS THE PROPERTY OF ACTIVE TECHNOLOGIES LTD AND MUST NOT BE REPRODUCED OR COMMUNICATED WITHOUT AUTHORITY	DATE -	21/04/20		
	CHECKED -	S.HOW		
CAD PLOT DO NOT SCALE	APPROVED -	A.CLIFTON		
		DRAWING TITLE	2 STAGE MAGNA CORDIS- PRESSURE PUMP-SHORT NOSE- 22.0 Ltr	
		DRAWING NUMBER	104-103-00031	