

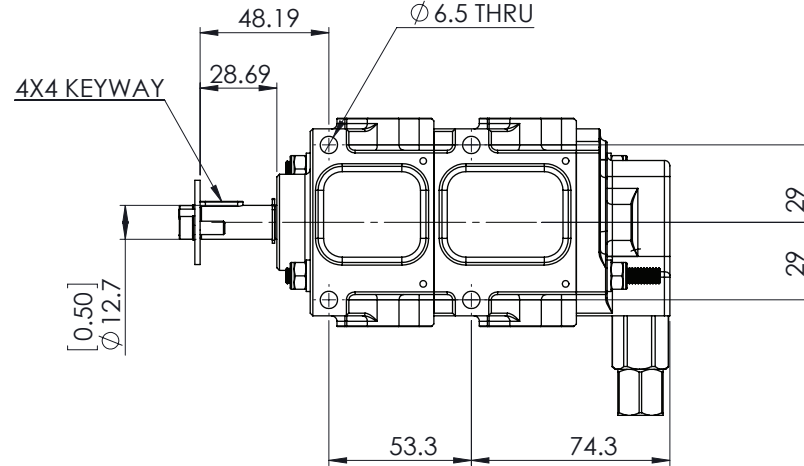

NOTES:

1. DISPLACEMENT PER REVERLUTION PER STAGE = 11.9 CC/REV
2. DISPLACEMENT AT 1000 RPM = 11.9 LT/MIN
3. PRV CRACKING PRESSURE:-
MINIMUM = 2.9 BAR (42 PSI)
MAXIMUM = 8.27 BAR (120PSI)
4. FOR EACH FULL TURN OF THE ADJUSTER THE CRACKING PRESSURE WILL INCREASE/DECREASE BY 0.25 BAR (3.6 PSI)

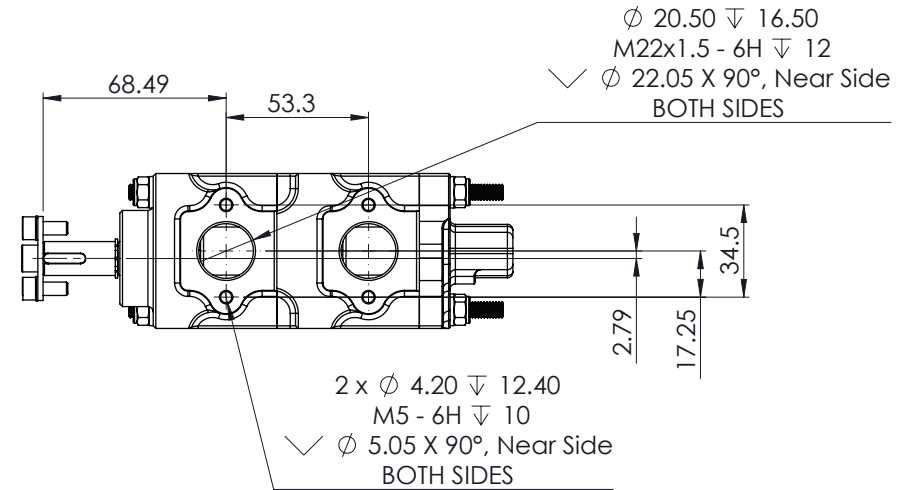
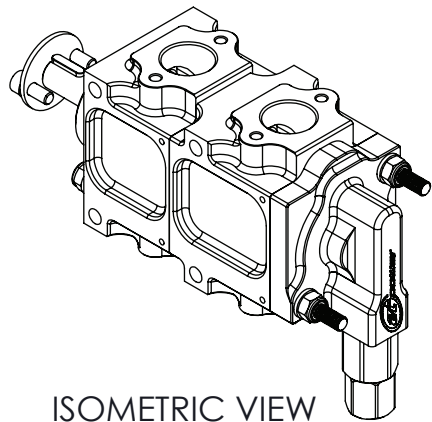
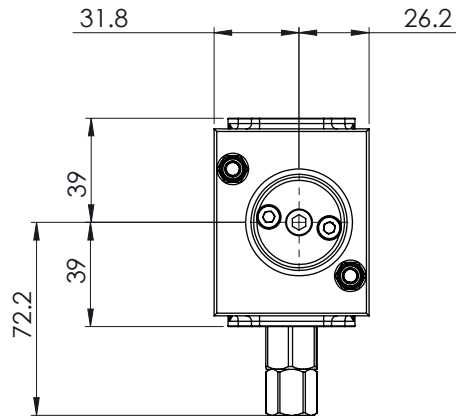
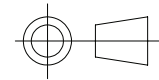

 COPYRIGHT (c) 2013 AT POWER LTD UNIT 9, CHESTNUT DRIVE, WYMONDHAM, NORFOLK, UK, NR18 9SB	 THIRD ANGLE PROJECTION	MATERIAL	SEE COMPONENT PARTS
		FINISH	SEE COMPONENT PARTS
UNLESS OTHERWISE STATED: DIMENSIONS IN MILLIMETRES TOLERANCES: LINEAR \pm 0.1 ANGULAR \pm 0.5° SURFACE FINISH \checkmark = ∇ DRAWING STANDARDS TO ATQS 6003 DATE FORMAT: DD/MM/YY	SCALE	WEIGHT	DRAWING TITLE
	1:2	-- kg	
THIS DESIGN IS THE PROPERTY OF ACTIVE TECHNOLOGIES LTD AND MUST NOT BE REPRODUCED OR COMMUNICATED WITHOUT AUTHORITY	DRAWN-	S.HOW	DRAWING NUMBER
	DATE -	23/04/20	
CAD PLOT DO NOT SCALE	CHECKED -	S.HOW	SHEET 2 OF 2 A3
	APPROVED -	A.CLIFTON	